



LB-200, LB-200G

Counter Model Batch Freezer



## STANDARD BATCHES WITH A COUNTERTOP MACHINE!

The New Carpigiani LB-200 machines are the ideal solution for small operations!

The manufacturer of the highest quality, easiest to use batch freezers on the market now offers a countertop solution to satisfy the demands of a growing market segment. Whether you want to make gelato, sorbets, ice cream, sherbet, or anything in between, you will find this machine a perfect fit.

This automatic batch freezer is very simple to operate. A novice will achieve great results on the first try, yet the flexibility for which we are famous will allow even the most demanding expert to be extremely creative. No other manufacturer offers this combination of quality and simplicity. In no time you will begin making smooth, creamy, irresistible frozen desserts!

### Features Include

- Available in Regular or Gelato versions
- Automatic operation with electronic consistency control
- Unique, cylinder design results in faster production and smoother finished product
- Audible alarm signals when product is ready to extract
- Cam door latch provides quick interior access
- Door material provides improved insulation, reducing power consumption
- Auger design provides optimal extraction, minimizing flavor overlap



Emerald City Espresso Machines 1915 - 1st Ave. South Seattle, WA 98134  
Seattle area phone: 206-935-0663 Toll free: 1-888-935-0663 FAX: 206-264-0782



Carpigiani is also the world's leading provider of hands-on frozen dessert instruction.  
Find out more at [www.gelatomachines.com](http://www.gelatomachines.com)

# SPECIFICATIONS

## MODELS LB-200 / LB-200G

Single speed counter model for low volume requirements

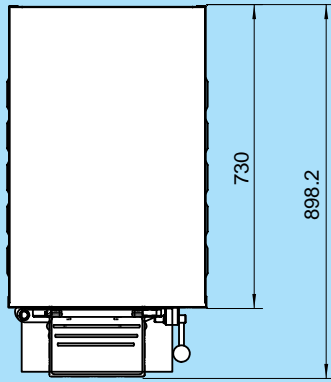

PLAN VIEW

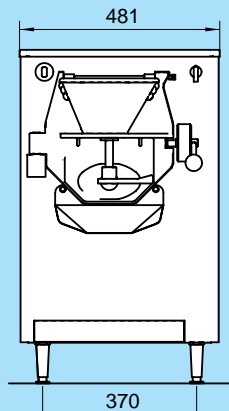

FRONT VIEW

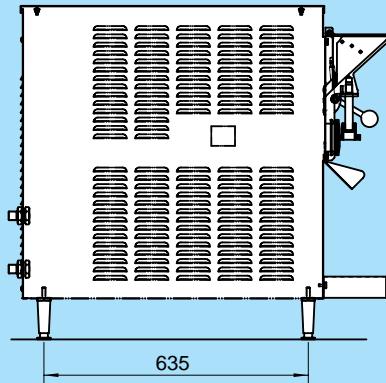

SIDE VIEW

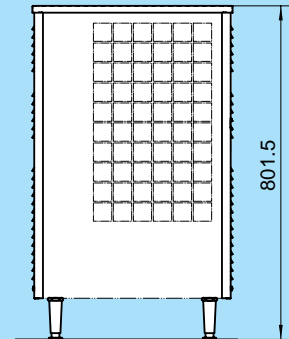

REAR VIEW

Model LB-200, LB-200G Description		
Cylinder Capacity (without beater)	10 Qts	
Hourly Production*	MIN.....	44 lbs
	MAX.....	66 lbs
Cylinder Refrig. Control System	Electronic Consistency Control	
Cylinder Type	Helicoidal Path	
Compressor Motor	2 H.P.	
Water Connections	½" MPT	
Condenser Cooling	Air / Water	
Refrigerant Type	R-404A	
Frame Type	Counter Model	
Frame Construction	Welded Steel	
Outer Panels	Stainless Steel	
Footings	Steel Base	
Dimensions		
Width	Depth	Height
19" (480 mm)	29" (745 mm)	31.56" (801.5 mm)

\* Hourly production can vary depending on mix used and operating conditions. Data was collected at 77°F (25°C) ambient temperature.

Model LB-200 Details			
Beater	Drive Motor	1.5 hp	
	Design	3E (Unibody)	
Weight	Gross	359 lbs ( 163kg)	
	Net	341 lbs (155 kg)	
Electrical Requirements			
Voltage	Phase	Cycle	Breaker Size
208-230	1/3	60 Hz	40 Amps
Number of Feeders: 1			

Model LB-200G Details			
Beater	Drive Motor	1.5 hp	
	Design	Unibody w/ Replaceable blades	
Weight	Gross	359 lbs (163 kg)	
	Net	341 lbs (155 kg)	
Electrical Requirements			
Voltage	Phase	Cycle	Breaker Size
208-230	1/3	60 Hz	40 Amps
Number of Feeders: 1			

Carpigiani-USA manufactures a complete line of frozen dessert production equipment: Batch Freezers, Soft Serve Freezers, Yogurt Freezers, Slush Freezers, Milk Shake Machines, Granita Machines, Whipped Topping Dispensers, Frozen Custard Freezers, Specialty and Mix Processing Equipment, Display Cabinets...

**Something for Everyone!**

### Distributed by:

All technical data, pictures, and drawing contained in this document are not binding on the manufacturer, nor can the manufacturer be held liable for any modification of the machine, in part or in whole.